

# CONDORITO

Patricio Kunz Tomic 2003 ©

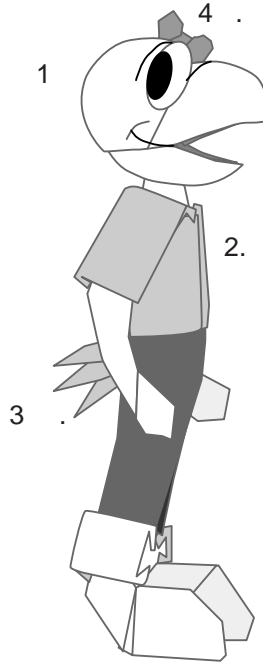
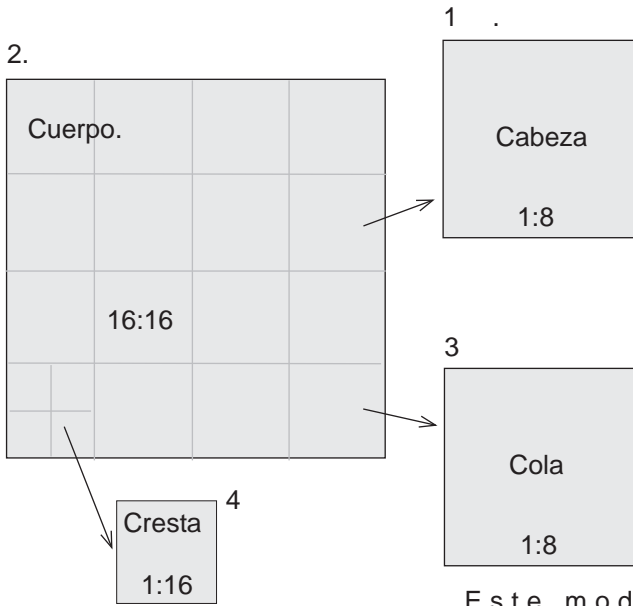

Este modelo se compone de cuatro partes. La cabeza, el cuerpo, la cresta y la cola. La proporciones son de 1:8 del cuerpo para la cabeza y la cola y de 1:16 para la cresta.

## Cabeza

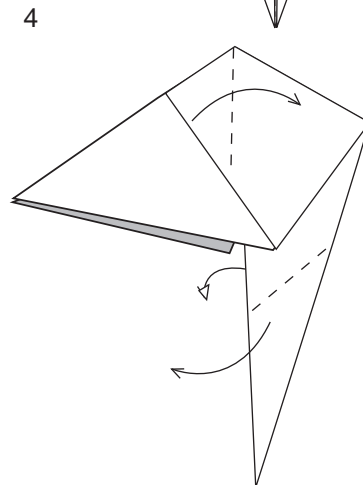
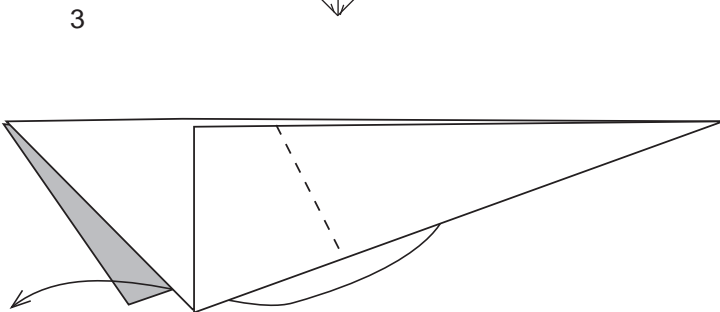
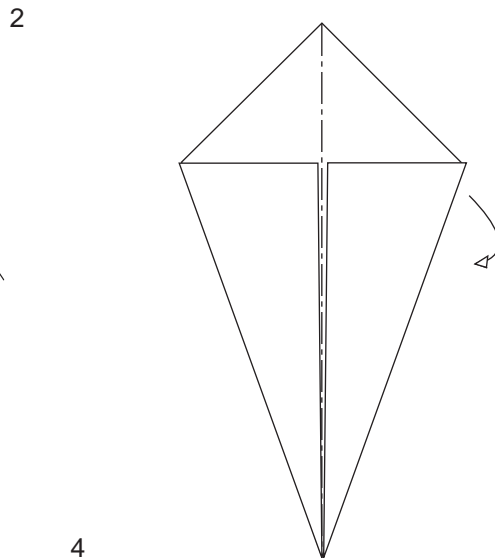
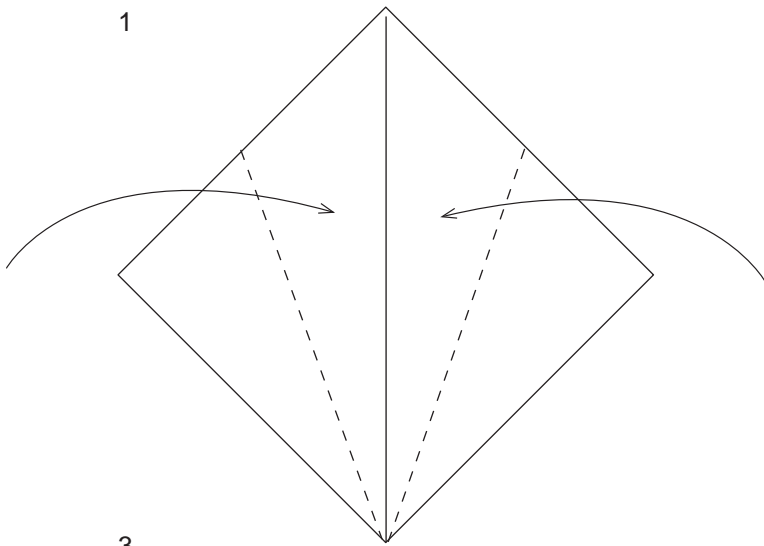

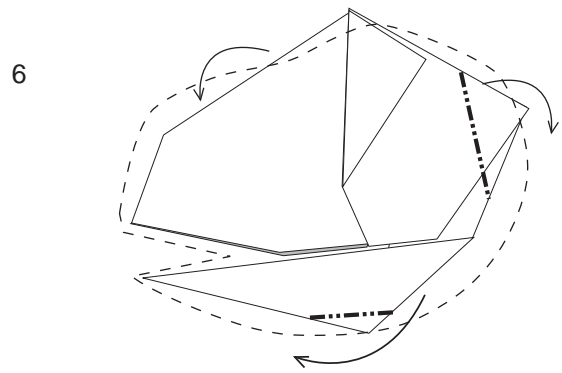
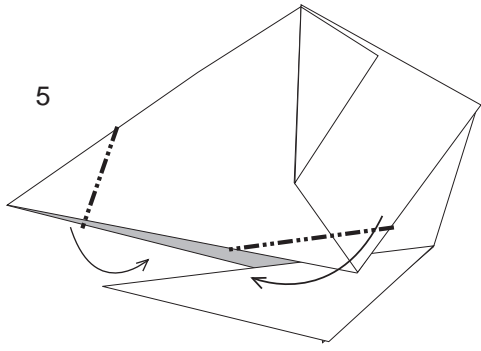

(Redondear cara )

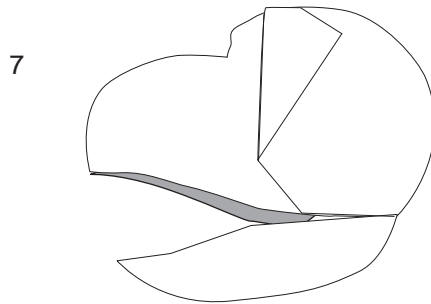

(Dar volumen a la Cabeza )

## Cresta

---

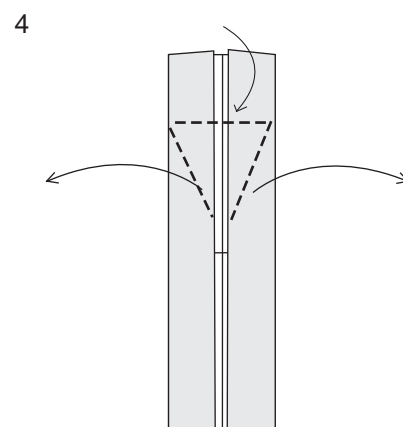
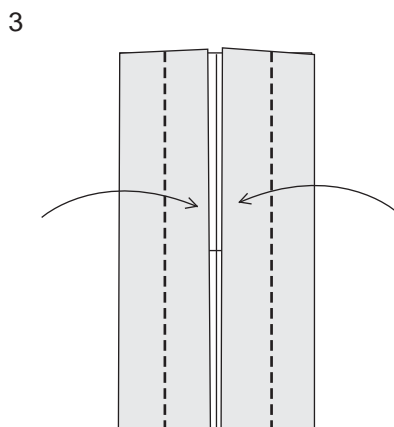
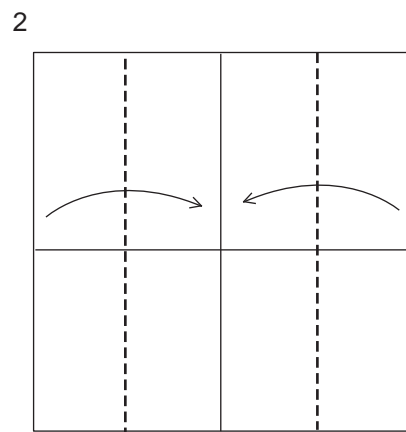
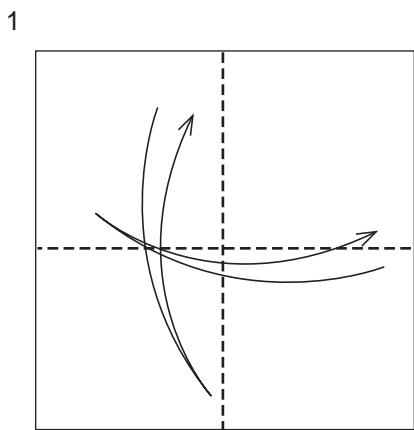

(doblar un poco antes de la mitad )

5

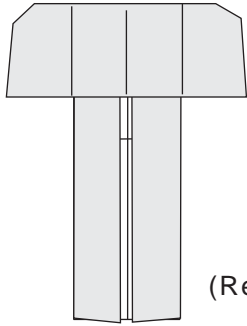

(Repetir paso 4 en parte inferior)

6

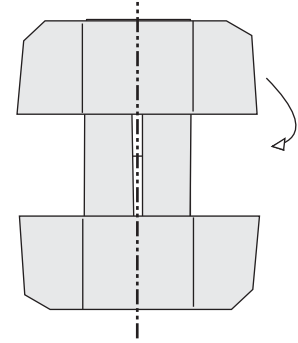

8

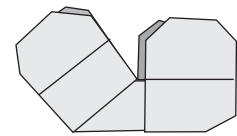

(Redondear la cresta)

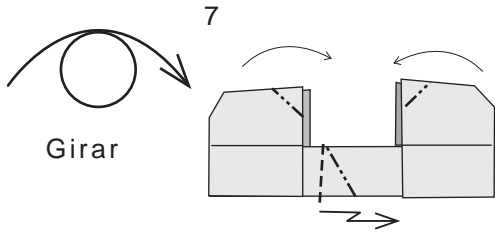

## Cuerpo

1

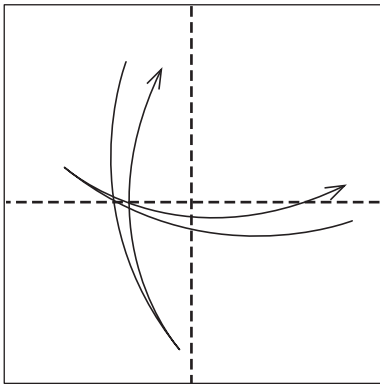

2

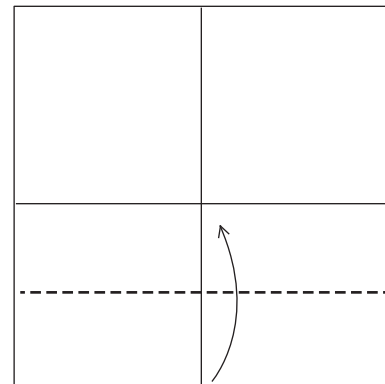

3

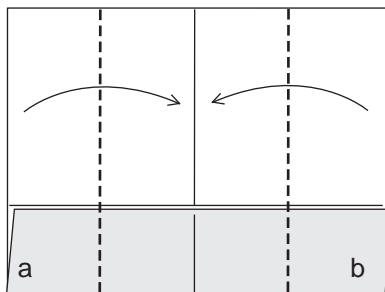

4

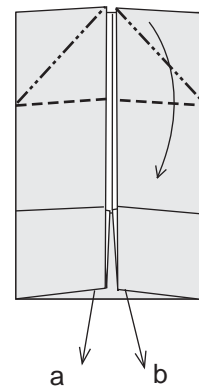

5

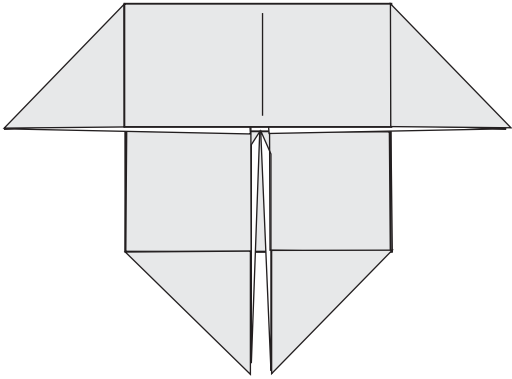

6

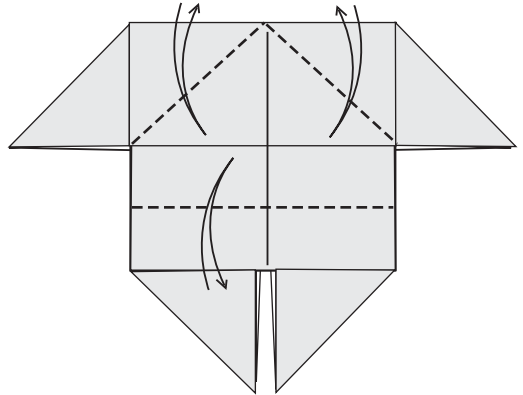

7

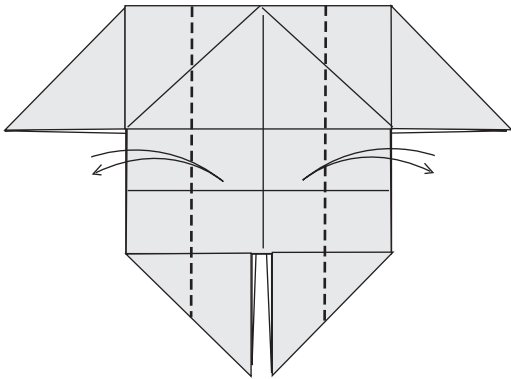

8

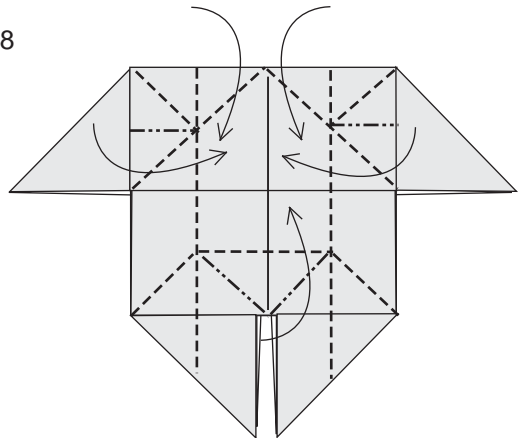

9

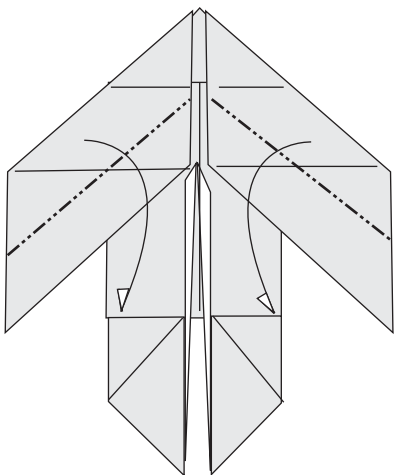

10

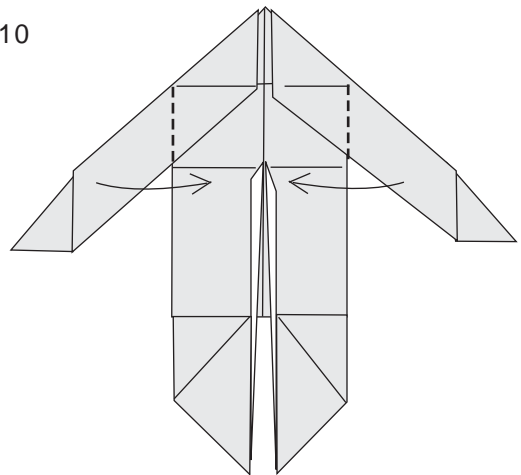

11

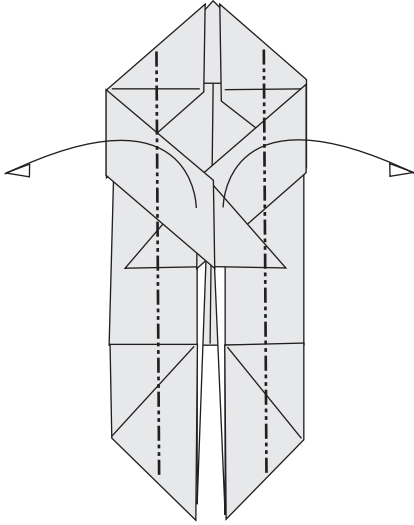

12

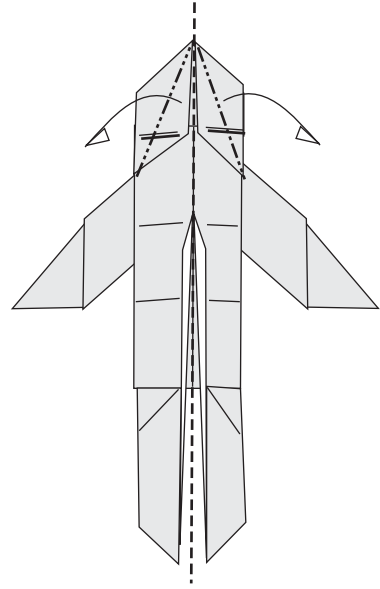

13

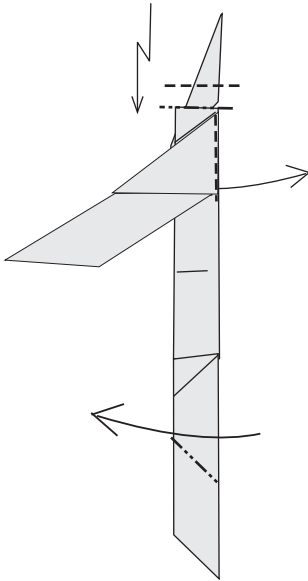

14

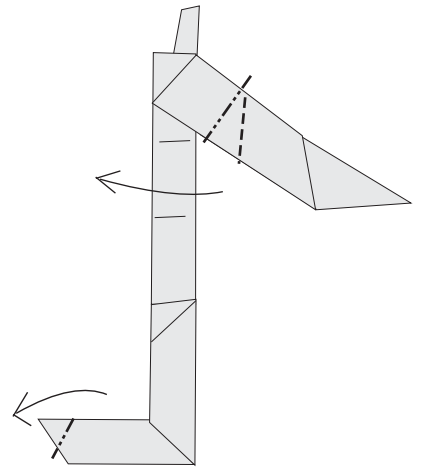

15

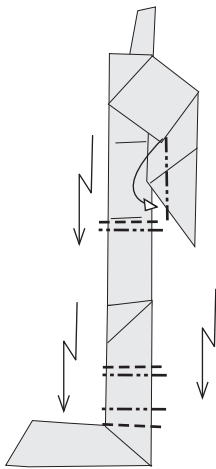

16

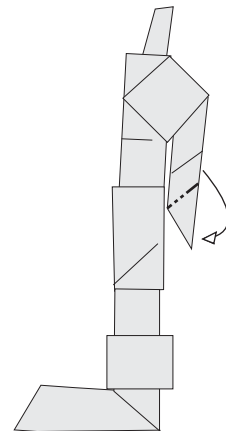

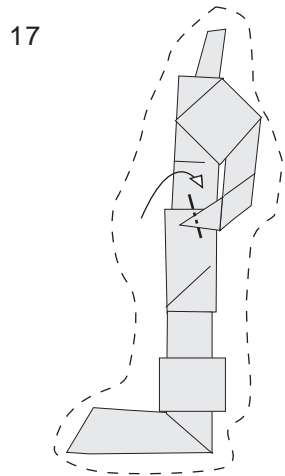

(Redondear la Figura)

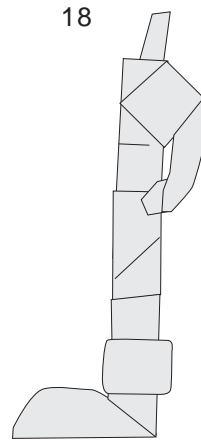

## Cola

---

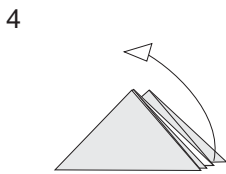
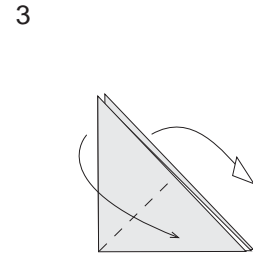
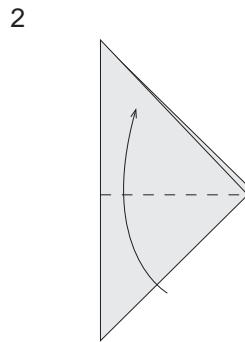
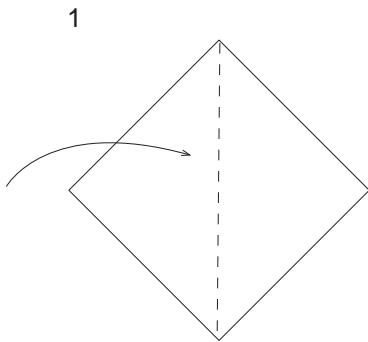

(Tirar la capa del medio)

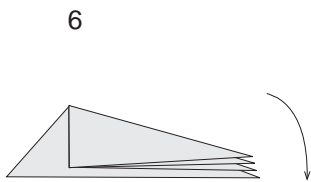
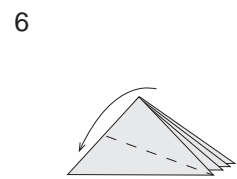
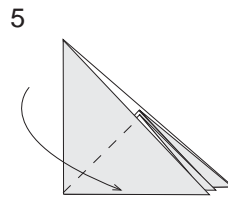

(Separar Plumas)

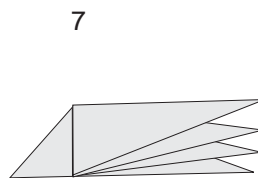

# Armado

---

... Colocar la cresta sobre la cabeza..

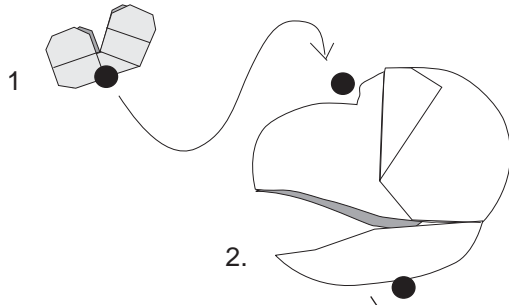

... Colocar la cabeza sobre el cuello...

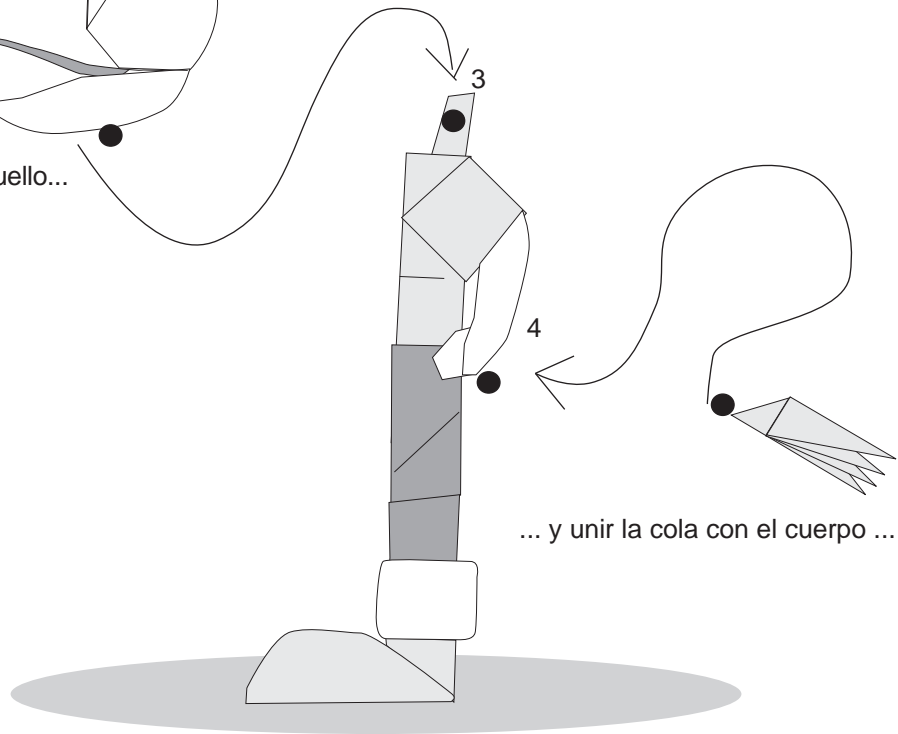

patokunz@hotmail.com

... Dibujar ojos y facciones para darle mas realismo al personaje...

# CONDORITO

